

# arla concrete countertop basin

# Kast



Concrete is a unique, timeless material. Our contemporary Kast range of basins are manufactured in England using traditional, aggregate-based concrete. They are available in a number of designs and colour variations. Every basin is made to order and the nature of the cement creates a solid and tactile aesthetic with organic stone-like characteristics, guaranteed to create a statement in any setting.

Arla is an elegant slim-edge countertop basin with subtle curves and a contoured bowl.

Dimensions	400mm(w) x 400mm(p) x 140mm(h)
Material	concrete
Finish	storm, duck egg, forest, ember, blush, zinc, stone, white, other colours upon request
Tapholes	nth
Overflow	no
Weight	tbc kg
Characteristics	see page 3

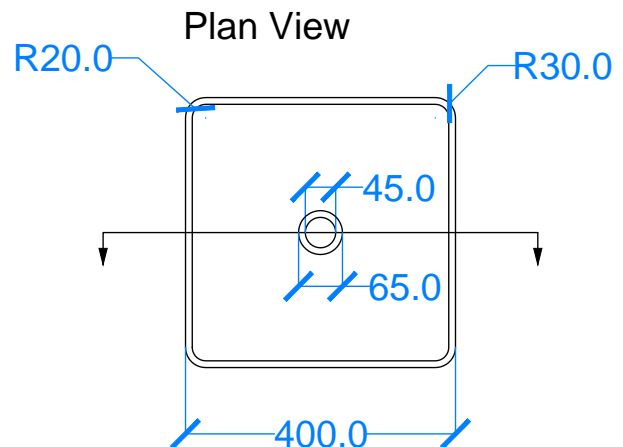

# M T I

Side View

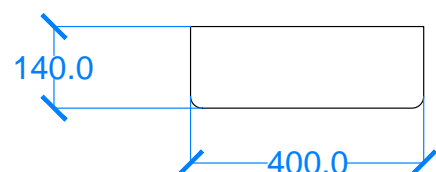



White



Ash



Ivory



Fossil



Stone



Zinc



Iron



Black



Peach



Blush



Ember



Brick



Wheat



Oyster



Sandcastle



Golden



Sage



Mint



Green



Forest



Heather



Dove



Duck Egg



Teal



Mineral



Steel



Blue



Storm

Kast basins are manufactured using traditional, aggregate-based concrete. The unique combination of aggregates naturally enhances the strength of the concrete and provides volume stability and durability. The depth of texture that occurs visually as a result of carefully blended aggregates and cement creates a solid and tactile aesthetic with organic stone-like characteristics.

## Typical characteristics include:

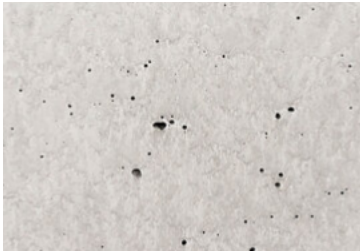

### Bug holes

Due to the nature of the casting process, air trapped within the concrete can sometimes cause small holes to form within the surface. These can vary in size and add to the distinctive texture and aesthetic of concrete.



### Exposed Aggregates

Kast concrete basins are manufactured using a traditional mix of aggregates, sand and cement. In some cases the aggregates may be visible within the surface of the concrete which is part of the unique, natural texture.



### Surface colour variation

Concrete will never be a monotone block colour due to the number of variable materials from which it is made. The variations in tone and texture create a unique patina that is integral to the character of concrete.

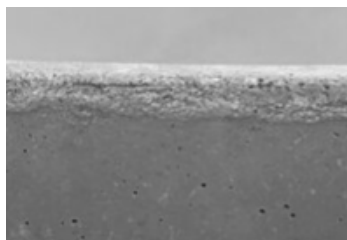

### Edge patination

Some basins require two-part moulds which can result in a different texture around the edge where the two moulds meet. This is where moisture within the mix can evaporate out at the seam creating a more raw, distinguished texture.



### Textural Flow Lines

The liquid state of concrete when it is being cast means that textural flow lines can sometimes be visible on the surface of the concrete. This tends to be more visible when casting curved or tall vertical surfaces and is another typical characteristic of concrete.



### Crazing

Small, fine cracks on the surface of concrete are very common within the long curing process and do not impact the structural quality or performance of the basin.